

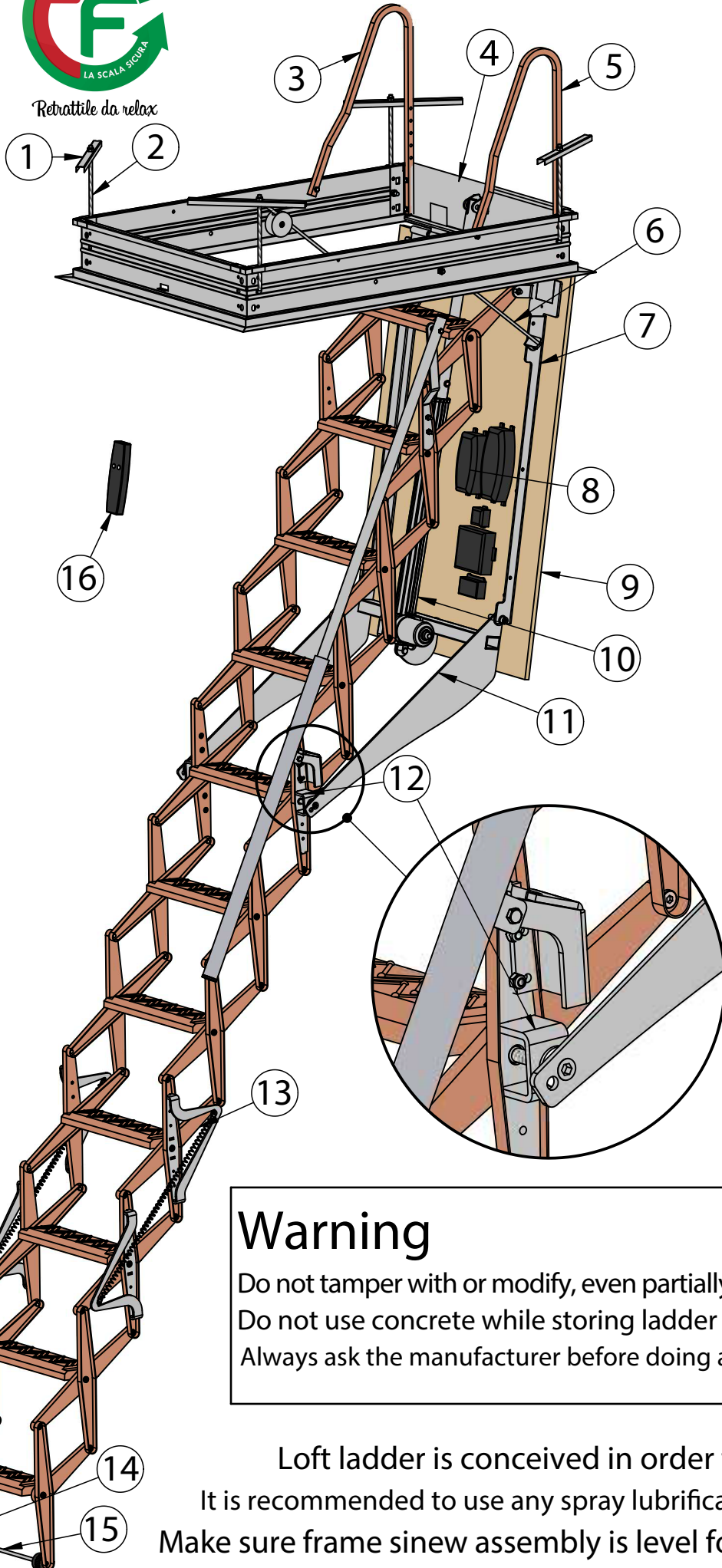

# THE SAFE LADDER 'AUTOATTIC® Vip H300'

Retrattile da relax



N.	Product description
1	Hanger bracket
2	Turnbuckle support
3	Anchoring left rail
4	Frame sinew ZN 12/10
5	Anchoring right rail
6	Scroll rod
7	Left base pantograph unit
8	Lithium back up battery
9	Multilayer panel
10	Linear actuator 24 dc 110/220V
11	Cluster group support
12	Joint oval tubular
13	Loft ladder tread
14	Antiskid wheel
15	Stabiliser bar
16	Steel remote

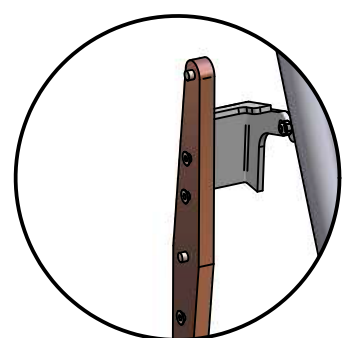
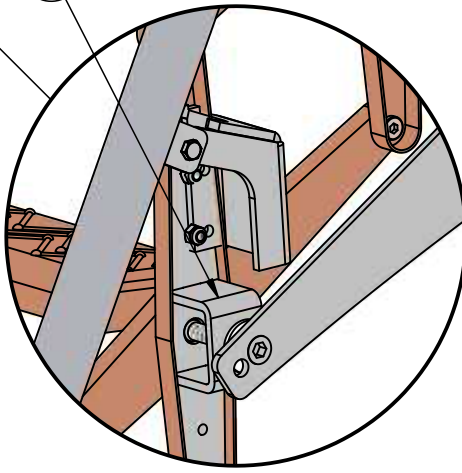

## Warning

Do not tamper with or modify, even partially, the ladder  
 Do not use concrete while storing ladder into ceiling  
 Always ask the manufacturer before doing adjustment



Loft ladder is conceived in order to be 66° incline

It is recommended to use any spray lubricant on levers and hinges

Make sure frame sinew assembly is level for a proper functioning

Manufacturer reserves the right to modify the device at any time without any prior notice



. La presente invenzione riguarda una scala perfezionata per l'apertura e chiusura di vani, in particolare per l'accesso a botole da soffitta o da terrazza.

. Il brevetto N° 0000280710 riconosce un sistema meccanico d'avanguardia e innovativo, permettendo la personalizzazione del pannello di copertura in ambito industriale.

. In sostanza, il pannello di copertura in legno è montato sulla scala a mezzo di calamite, offrendo all'occorrenza lo smontaggio e il rimontaggio rapido dello stesso; in questo modo l'ispezione della botola è garantita in ogni momento risulti necessario e senza l'ausilio di attrezzature.

. The present invention relates to a refined loft ladder for opening and closing of compartments, particularly for gaining access to loft or terrace hatches.

. The patent No. 0000280710 recognises a well-advanced and innovative mechanical system, allowing a manufactured covering panel customization.

. Basically, the covering panel, made of wood, has been assembled by means of magnets on the loft ladder, ensuring if necessary a quick removal and putting back of it; this way, the hatch viewing is assured whenever necessary and without using specific tools.

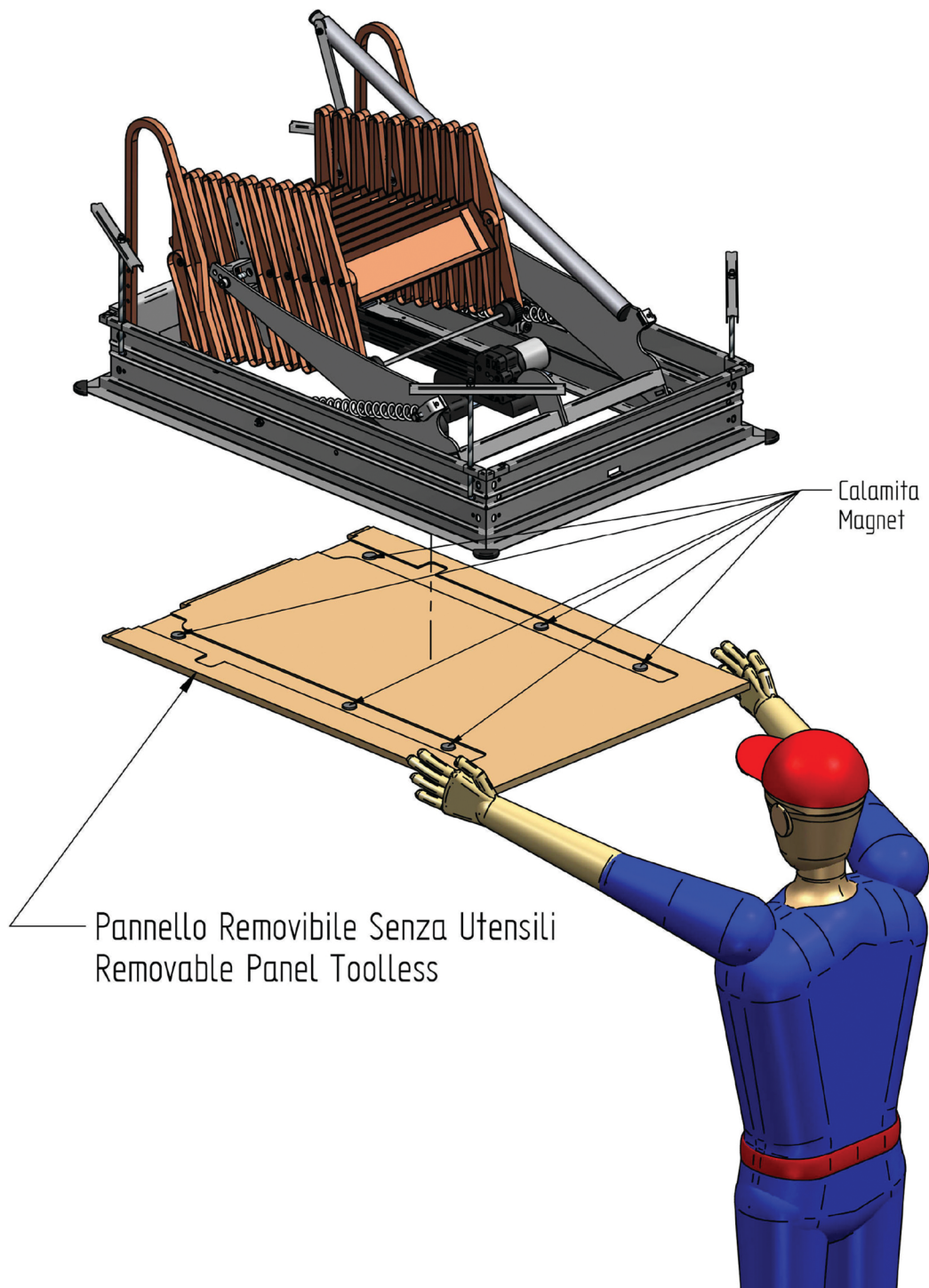

## Wide step

Step on ladder fitting hatch door  
hole sizing from cm 65 and more

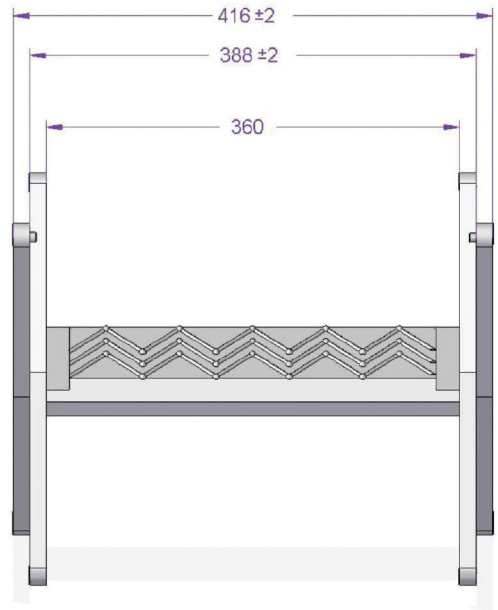
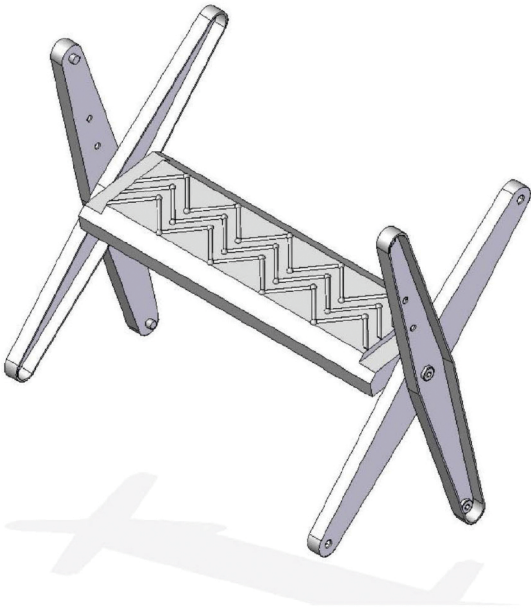

## Small step

Step on ladder fitting hatch door  
hole sizing until cm 60 and less

